



VORTEX FLUID SYSTEMS INC.

vortexfluidsystems.com

ORBITAL 3 PANEL MUD CLEANER

DESCRIPTION

The Orbital 3 Panel Mud Cleaner features a very compact design capable of processing 1000 GPM of drilling mud. This mud cleaner has 22.5 ft of screening area and produces 6.6 g's of acceleration. The hydrocyclone manifold has ten high performance 4 inch cones each capable of processing 100 gpm each.

HYDROCYCLONE MANIFOLD

The hydrocyclone manifold has ten premium four inch hydrocyclones in a linear configuration with a total processing capacity of 1000 GPM. Each hydrocyclone is capable of processing 100 GPM and comes with a head, straight cylindrical, and a cone section. The tip of the cone section has a polyurethane nut and adjustable nozzle wear piece. The feed and overflow for the manifold are 6 in [15.25 cm] diameter. Holes for optional pressure gauges are mounted on the feed tube.

HYDROCYCLONE ACCESS

The Orbital 3 Panel mud cleaner has the hydrocyclones mounted above the steel plate in front of the first screen. This configuration greatly reduces the overall height of the shaker while allowing room to conveniently access the hydrocyclones. Since the Hydrocyclones discharge on a steel plate, and not on the screen directly, is greatly beneficial to screen life.

POLYURETHANE

The polyurethane used to cast these hydrocyclones is a proprietary blend. In testing, this blend has shown to significantly exceed 90% alumina ceramic in abrasion wear resistance. Since these cones have better wear properties than our ceramic lined cones, Vortex no longer produces cones with ceramic inserts.

HEAD SECTION

The hydrocyclone head has both a ramped and involute, entry to allow for greatly enhanced wear properties and better performance than many standard hydrocyclone heads.



FEATURES

- ☑ SCREEN AREA: 22.5 ft²
- ☑ ACCELERATION: 6.6 g's
- ☑ COMPACT UNIT: low height, small footprint
- ☑ PROCESSING CAPACITY: 1000 gal/min
- ☑ POLYURETHANE: low wear proprietary blend
- ☑ FASTENERS: stainless steel
- ☑ SEAL WELDED: base, basket, and manifold are all seal welded
- ☑ COATING: two layers of powdercoat
- ☑ CONE NOZZLE DIAMETER: adjustable with a polyurethane nut and nozzle wear piece
- ☑ FASTENERS: stainless steel
- ☑ U-JOINT: polyurethane replaceable
- ☑ PRESSURE SENSOR MOUNT: two holes for optional feed pressure sensor



VORTEX FLUID SYSTEMS INC.
Serving our customers worldwide...

www.vortexfluidsystems.com
office: 918.810.7798 • fax: 918.492.1688



VORTEX FLUID SYSTEMS INC.

vortexfluidsystems.com

SPECIFICATIONS AND DIMENSIONS

SHAKER SPECIFICATIONS

NAME: Orbital 3 Panel
SCREEN AREA: 22.5 ft ² [2.8 m ²]
"G" FORCE: 6.6 g's, 7.5 g's (optional)
MOTION: Progressive Elliptical
DIM. (LxWxH): 97-7/8x72-1/2x75-1/8in
DIM. (LxWxH): 251x78x44cm
BASE DIM. (LxW): 83-1/5x61in (212x155cm)
TOTAL WEIGHT: 3980lb [1769kg]
ADJUSTMENT ANGLE: 0 to 8 degrees
ANGLE CHANGE: hand crank
SCREEN TYPE: pretension
SCREEN NUMBER: 3 screens
SCREEN SIZE: 48 x 24 in [122 x 61 in]
MOTORS: Itolvebras, 1200 rpm, 1800 rpm

MANIFOLD SPECIFICATIONS

NAME: 10 Cone Linear
NUMBER OF CONES: 10
CONE TYPE: 4 in
CONE CONFIGURATION: LINEAR
PROCESSING CAPACITY: 1000 GPM
INLET PRESSURE: 70 feet of head
NOZZLE ADJUSTMENT: polyurethane nut
FEED DIAMETER: 6 in victaulic
OVERFLOW DIAMETER: 6 in victaulic
PRESSURE SENSOR: 3/4 in femail fitting

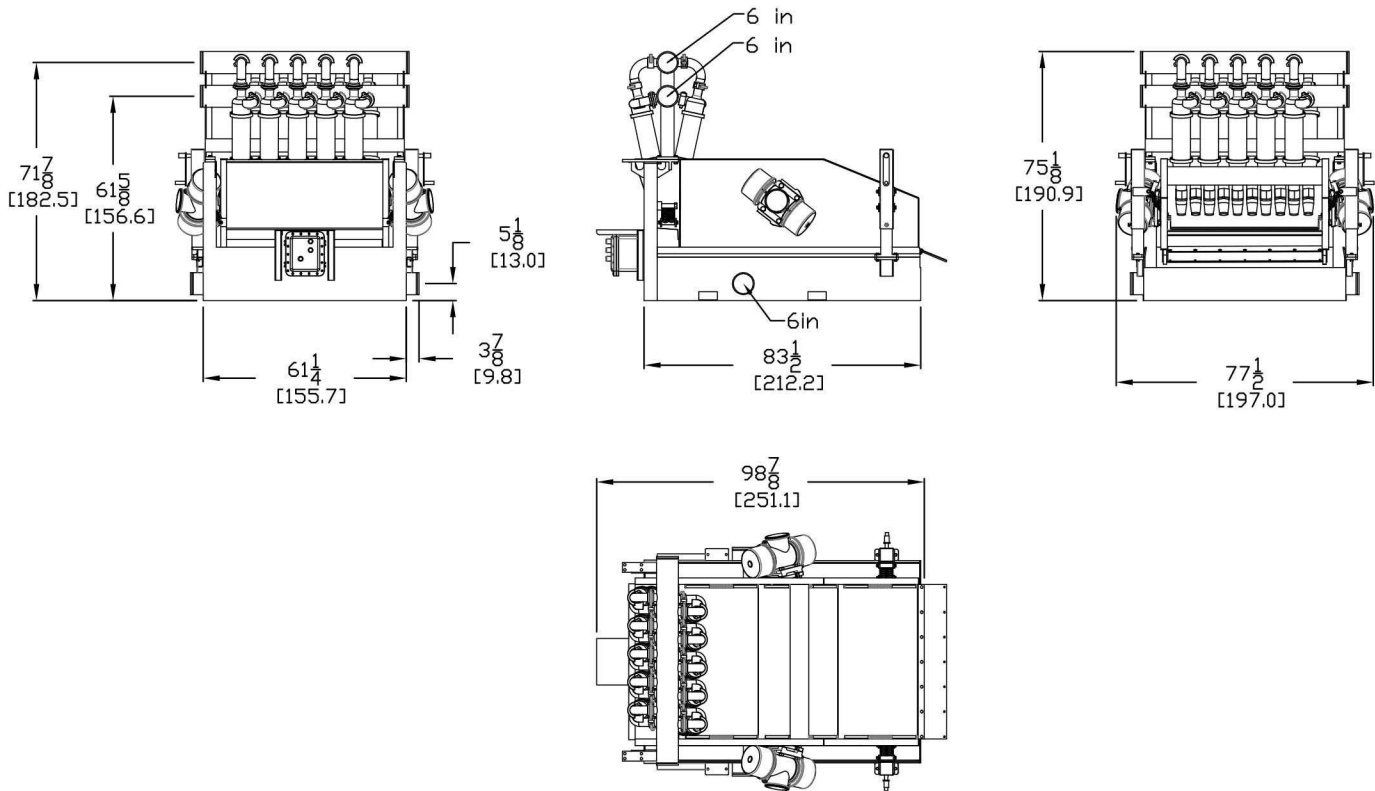

VORTEX FLUID SYSTEMS INC.
Serving our customers worldwide...

www.vortexfluidsystems.com
office: 918.810.7798 • fax: 918.492.1688